S718 MANUAL

SURFACE GRINDER

P A R T S • L I S T S



K. O. LEE COMPANY • 200 S. HARRISON
ABERDEEN, SD 57402-1416 • PHONE (605) 225-5820

MAIN ASSEMBLY DRAWING

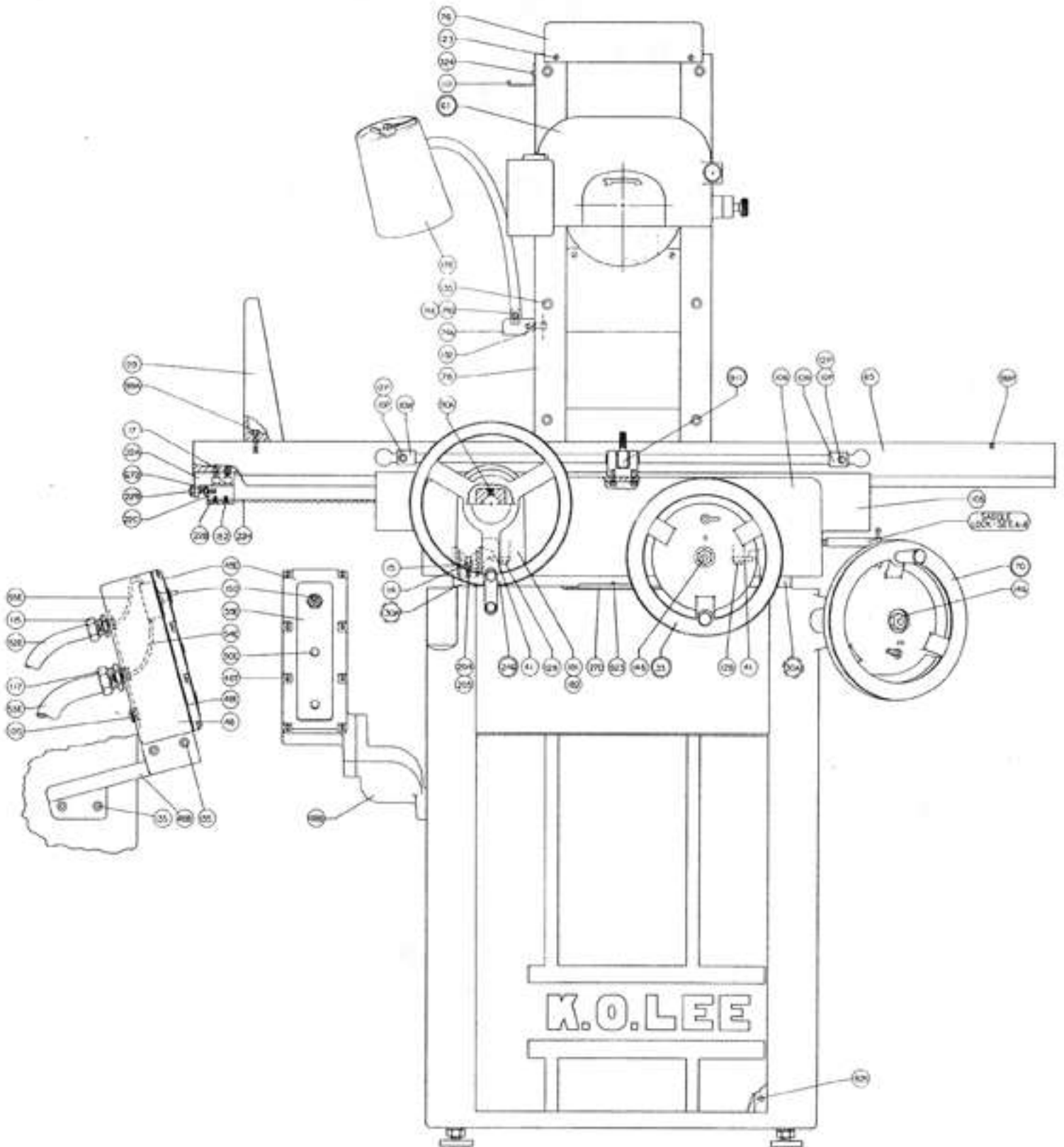

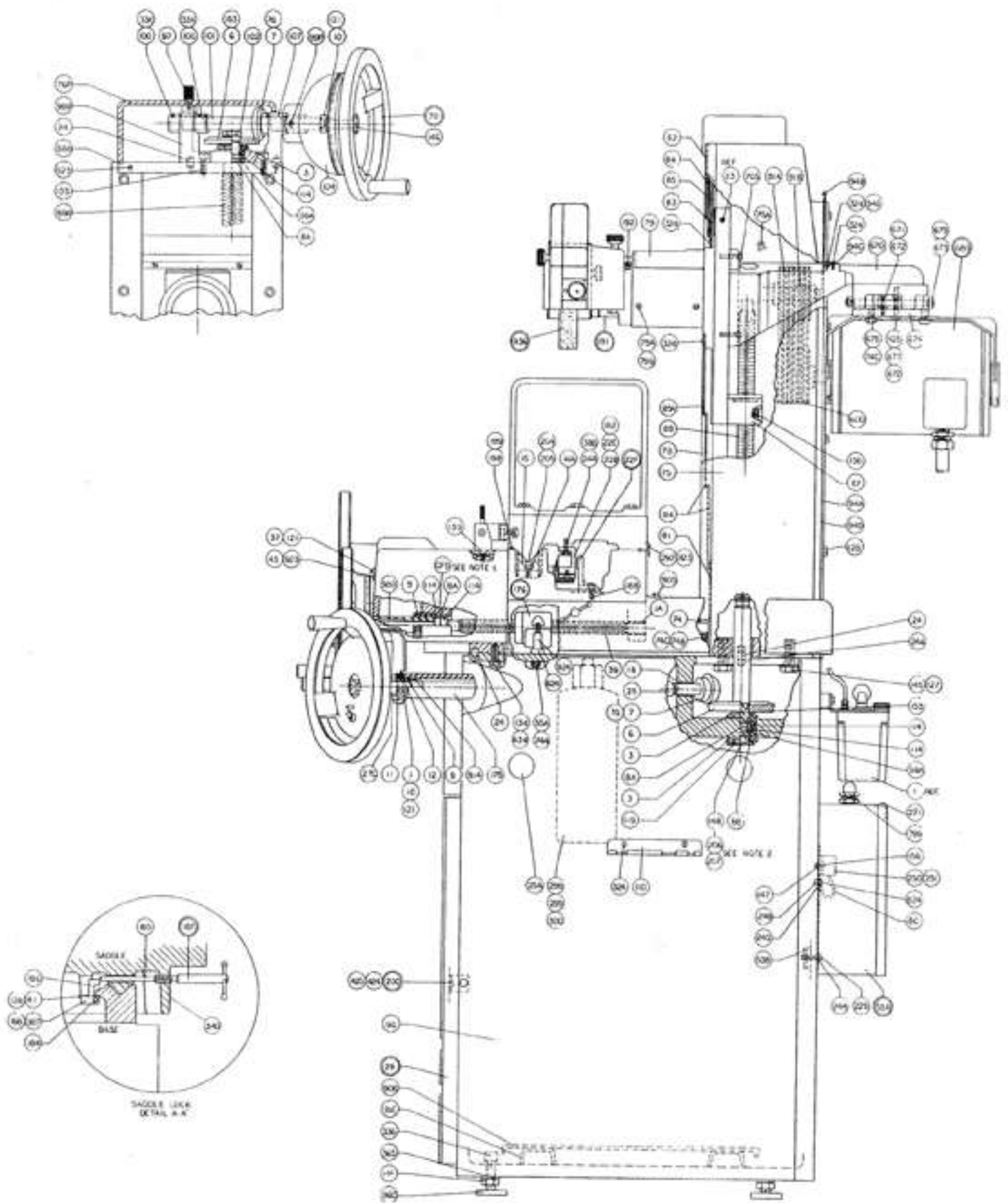

S718 SURFACE GRINDER PARTS LIST

INDEX NO.	PART NO.	DESCRIPTION	QTY.
1A	Y11-1404	M10121 Needle Bearing	1
3	B805M	Adjusting Nut	2
6	S626G	Gear	1
7	S626P	Pinion Gear	1
7G	Y15-02113163	3/16 x 3/16 NC Hex Soc. Set Sc.-Cup	1
8A	B830SY5	Circular Shim	2
8C	B865BG	Electric Wire	1
9	BA805N	Lock Nut	1
10	BA805P	Indicator Plate	1
10P	B810P	T-Slot Plate	2
10W	B810W	Adjustable Stop	2
12P	Y13-03231024	3/16 x 3/4 NF Hex Soc. Cap Screw	2
14	B930RP2	Oil Roller Plate	8
14A	B930RP	Oil Roller Plate	6
15	B1030PR	Oil Roller	14
17	Y13-03225012	1/4 x 5/8 NF Hex Soc. Cap Screw	2
20C	B965DD	Door Catch Assembly	1
22A	S710W2	Belt Tension Bracket	1
22B	S710W7	Clamp with Teeth	2
22C	S710W8	Plain Clamp	1
22E	S710W10	Belt Anchor Bracket	1
22F	S710W16	Bracket and Roller	1
22H	S710W30	Timing Belt	1
24	BA905DP	Dowel Pin	5
24A	BA905DPL	Dowel Pin	1
25A	BA905HP	Hole Plug	6
27D	BA905CP	Cover Plate	1
28	BA965DH	Door and Hinge	1
30A	B2005A	Base Way Vee Assembly	1
33	B6012C	Handwheel Assembly	1
33X	Y15-02211015	10-32 x 3/16 Hex Soc. Set Sc.-Cup	4
35A	Y13-03238038	3/8 x 1 1/4 NF Hex Soc. Cap Screw	2
37	BA930P	Indicator Plate	1
39	S930SF1	Feed Screw	1
41	BA930TT	Hold Down-Short	4
43	B6030WB	Bracket for Index	1
48	BA967B	Switch Box	1
48B	BA967A4	Bracket for Box	1
48E	BA967G	Gasket	1
48T	Y14-11231013	10-32 x 3/4 S. T. Rd. Hd. Mach. Sc.-NP	8
49E	BA967C	Cover	1
50E	BA967CP	Plug	2
52E	BA967H54	Flexible Conduit	1
53A	BA967KB	Cut Out Box	1
53B	BA967KC	Screw Clamp	4
53E	BA967J32	Flexible Conduit	1
54E	BA967W52	Power Wire	3
55E	BA967W72	Power Wire	3
59E	Y12-0115	KO-29 Name Plate	1
61	S709	Wheel Guard Assembly	1
65	S710	Table	1
70	S812D	Handwheel	1
70S	Y13-02231033	3/16 x 7/8 NF Hex Hd. Cap Sc.-NP	4
74	S625A	Guard Stop	1
74A	S625B	Bracket for Lamp	1
74B	Y13-03131067	3/16 x 1/2 NC Hex Soc. Cap Screw	2
74C	Y16-06233107	3/16 NF Steel Washer - Plated	6
74D	B923LS	Lamp Stud	1
74E	Y13-02231030	3/16 x 5/8 NF Hex Hd. Cap Sc. - NP	1
75	S625C	Box Column	1
75A	Y11-2201	No. 434 Nylon Hole Plug	2
76	S725CP	Column Cap	1
78	S625R	Guide Rail	2
79	S625S-1	Column Slide	1
79A	S625SP	Plug	4
79B	Y15-02214448	7/16 x 3/8 NF Hex Soc. Set Sc. - Cup	4

INDEX NO.	PART NO.	DESCRIPTION	QTY.
81	S625TAS	Telescoping Guard	1
82	S625TB	Telescoping Guard	1
83	S625TC	Telescoping Guard	1
83A	S625TCS	Telescoping Guard	1
84	S625TD	Telescoping Guard	1
85	S625TE	Telescoping Guard	3
87	S626B-1	Column Feed Nut	1
89A	S726SF	Elevating Screw	1
90A	Y15-02232526	1/4 x 1/4 NF Hex Soc. Set Sc. - 1/2 D	1
90B	BA905BW	Plate for Tank	1
91A	S655H3	Pulley	1
91B	S855K	Key	1
91E	BA905BUL	Bracket	1
94A	S826TG	Guide Bar	2
94B	S826TR	Removable Guard	2
94C	S826TU	Upper Guard	1
94D	S826TL	Lower Guard	1
94G	Y16-02211012	10-32 Std. Light Hex Nut - NP	1
96	S805RE	Base	2
96C	BA905GR	Leveling Pad Assembly	1
97	S725S	Screw for Column Cap	4
98A	S726A	Bushing	1
99	S610G	Guard	1
99A	Y13-02225010	1/4 x 3/8 NF Hex Hd. Cap Sc. - NP	1
99B	S726GB	Bracket	3
99P	Y15-02212525	1/4 x 1/4 NF Hex Soc. Set Sc. - Cup	1
100	S726C	Thrust Collar	3
101	S726E	Handwheel Shaft	2
102	S726N	Special Nut	1
104	S726GC	Bell End for Bracket	1
105	S8030VT	Saddle	1
106	S730WG	Front Shroud	1
107	Y11-1504	AA-710-16 Oilite Bearing	1
110	S890B	Tool Rack	2
111	S890C	Rack for Wrench	1
114	Y11-1219	S7K2 Bearing	1
115	Y17-0515011	75-221 1/2" Straight Connector	4
117	Y17-0517515	75-222 3/4" Straight Connector	2
120	Y11-2205	Cup No. 1 1/2" Close Up Plug	2
121	Y14-11131301	2 x 1/8 S. T. Rd. Hd. Sc. - Type F - NP	1
127	Y13-02150128	1/2 x 1 1/4 NC Hex Hd. Cp. Sc. - NP	4
128	Y13-02225004	1/4 x 1/2 NF Hex Hd. Cap Sc. - NP	4
132	Y13-02131079	5/16 x 1 1/4 NC Hex Hd. Cap Sc. - NP	18
134	Y13-02244145	7/16 x 1 1/4 NF Hex Hd. Cap Sc. - NP	2
135	Y13-03131069	3/8 x 1 1/4 NF Hex Hd. Cap Sc. - NP	6
138	Y13-03231030	3/8 x 3/4 NC Hex Soc. Cap Screw	12
139	Y13-05222506	3/8 x 2 NF Hex Soc. Cap Screw	2
145	Y16-135001	1/4 x 5/8 NF Fl. Hd. Soc. Cap Screw	4
146	Y16-02224436	1/2 External Shakeproof Washer	4
147	Y18-02110808	7/16 Std. Light Jam Nut - NP	2
148	Y16-02135063	8-32 NC Std. Light Hex Nut - NP	2
150	Y18-1207	1/2 NC Std. Light Jam Nut - NP	4
150	Y18-1218	N1030B Toggle Boot	1
153	Y16-2301	0140-3020 Switch	1
156	Y14-02130839	No. 2 Woodruff Key	4
176	BA924-1	8-32 x 3/8 Rd. Hd. Mach. Sc - NP	2
178	Y18-06901	Feed Nut Assembly	1
181	BA930WA3	0618-3 Light Fixture	1
182	Y13-05221002	Segment	1
184	BA919A	10-32 x 1/2 Flat Hd. Soc. Cap Screw	6
185	BA919P	Axle	1
186	BA919L	Plunger	1
187	B2019D	Lock	1
188	Y13-03231023	Lock Screw Assembly	1
191	S6055CL	5/16 x 5/8 NF Hex Soc. Cap Screw	4
192	Y11-1906	Quill Assembly	1
198	B2030HES	8041 O-Ring	1
199	B2030HD	Shim for Dust Shield	1
204	S2030NP	Saddle Way Dust Shield	1
		Nylon Plug	6

INDEX NO.	PART NO.	DESCRIPTION	QTY.
205	B931WS	Spring	6
221	Y14-12130605	6 x 3/8 S. T. Pan Sl. Bind Hd. - Type A	1
229	Y13-02225015	1/4 x 1 1/4 NF Hex Hd. Cap Sc. - NP	5
244	Y16-082502	1/4 Lock Washer -- Regular	6
245	Y16-081801	3/16 Lock Washer	1
246	S1029-3	Transmission	1
248	Y16-02211011	10-32 Std. Light Hex Nut - Brass	1
250	Y18-1609	CR151C10 End Block	1
251	Y18-1608	CR151C2200 Terminal Block	8
292	S930HE	Dust Shield	1
298	Y11-01019	28/410 32oz. Clr. Plastic Bottle	1
299	BA905N	Special Nut	1
300	Y17-072513	1/4 x 3 Long Pipe Nipple	1
324	Y14-02231058	10-32 x 1/4 Rd. Hd. Mach. Sc. - NP	12
336	Y15-03115013	1/2 x 2 1/2 NC Sq. Hd. Set Sc. Cup Pt.	4
340	Y12-0124	KO-40 Name Plate	1
365	Y16-085007	1/2 Lock Washer	4
388	Y13-02225007	1/4 x 5/8 NF Hex Hd. Cap Sc. - NP	2
424	Y14-02231069	10-32 x 1/2 Rd. Hd. Mach. Sc. - NP	2
425	S6012W	Washer No. 12	2
600	Y11-1931	AS568-349 O-Ring	6
624	B6024NS	Spacer for Feed Bar	1
634	Y16-134402	7/16 External Shakeproof Washer	6
670	S823S	Motor Bracket	1
671	Y13-02225013	1/4 x 1 NF Hex Head Cap Sc. - NP	1
672	Y16-02222527	1/4 NF Std. Light Jam Nut - Pltd.	3
673	Y16-02223165	5/16 NF Std. Light Jam Nut - NP	2
674	S623BL	Bracket	1
675	Y13-02231027	5/16 x 1/2 NF Hex Hd. Cap Sc. - NP	4
677	S623BM	Special Screw	1
679	S623BA	Axle	1
680	S823G	Motor Pulley Assembly	1
744	Y16-083805	3/8 Lock Washer -- Light	2
799	Y17-0537516	3/4" 90° Connector	1
823	Y13-04221001	10-32 x 1/4 But. Hd. Soc. Cap Screw	5
824	Y14-02241066	10-32 x 3/8 Rd. Hd. Mach. Sc. - Brass	1
825	Y13-04211009	10-32 x 1/2 But. Hd. Soc. Cap Screw	5
888	S725CB	Bar	1
905	Y11-1703	503 Gits Oiler	2
911	B911CS	Center Stop Block	1
923	Y14-11231010	10-32 x 3/8 S. T. Rd. Hd. Sc. - Type F - NP	5
924	BA924NB	Feed Bar	1
930	B930SV	Spacer	1
936	S936CL8W	Wheel and Coilet Assembly	1
987	BA919H	Holder for Axle	2
ACCESSORY	B936W	Spanner Wrench	1
ACCESSORY	S681	Diamond Dresser	1
ACCESSORY	S895	Wrench	1
ACCESSORY	S896	Wrench	1
ACCESSORY	PV8JM60	Grinding Wheel	1
SHIPPING	BA900RL	Table Clamp Rod	4
SHIPPING	S600GW	3/8 Special Washer	8
SHIPPING	S600RC	Rod Clamp	4
SHIPPING	Y13-02138106	3/8 x 5 1/2 NC Hex Hd. Cap Screw	4
SHIPPING	Y16-03213102	5/16 NF Hex Nut - Heavy	4
SHIPPING	Y16-02113852	3/8 NC Std. Light Hex Nut - NP	4
*	KO-111	Caution Label	1
*	S610P	Plug	1
*	Y12-01104	KO-100HV Danger HV	1
*	Y12-0148	KO-61A Name Plate	1
*	Y12-0151	KO-61D Name Plate	1
*	Y12-0152	KO-62 Name Plate	1
*	Y12-0153	KO-63 Name Plate	1
*	Y12-0157	KO-68 Protective Mat	1
*	Y12-0194	KO-61H Instruction Plate	1
*	Y14-02130001	0 x 3/16 Rd. Hd. Met Dr. Sc. - Type Y - NP	4
*	Y18-1103	41-609 Wire Tie	4

S1029-3 SURFACE GRINDER TRANSMISSION ASSEMBLY WITH BELT DRIVE

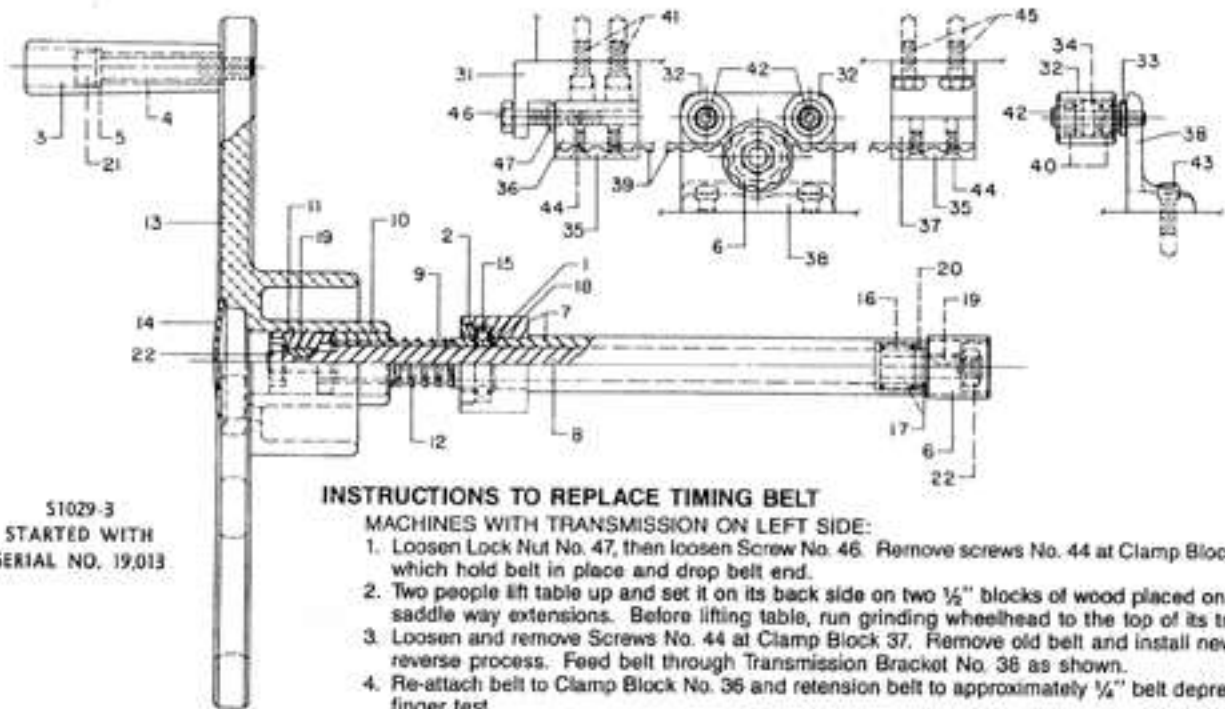

S1029-3
STARTED WITH
SERIAL NO. 19,013

INSTRUCTIONS TO REPLACE TIMING BELT

MACHINES WITH TRANSMISSION ON LEFT SIDE:

1. Loosen Lock Nut No. 47, then loosen Screw No. 46. Remove screws No. 44 at Clamp Block No. 36, which hold belt in place and drop belt end.
2. Two people lift table up and set it on its back side on two 1/2" blocks of wood placed on the rear saddle way extensions. Before lifting table, run grinding wheelhead to the top of its travel.
3. Loosen and remove Screws No. 44 at Clamp Block 37. Remove old belt and install new belt by reverse process. Feed belt through Transmission Bracket No. 36 as shown.
4. Re-attach belt to Clamp Block No. 36 and tension screw to approximately 1/4" belt depression by finger test.

MACHINES WITH TRANSMISSION ON RIGHT SIDE:

Reverse above procedure, working first from right end of machine where tension screw is located.

INDEX NO.	PART NO.	DESCRIPTION	QTY.	INDEX NO.	PART NO.	DESCRIPTION	QTY.
1	A804X	Washer	1	12	S729-10	Spring	1
2	B805N	Lock Nut	1	13	S1029C	Handwheel	1
3	S629AB	Grasp Handle	1	14	S1029D	Cap	1
4	S629ABI	Valve Guide	1	15	S7K	Ball Bearing	1
5	S629AW	Thrust Washer	1	16	BH-1010	Needle Bearing	1
6	S710W4	Pulley — Timing Belt	1	17	1R-061012	Inner Race	1
7	S729-4L	Stationary Shaft Assembly	1	18	RS-62	Spirolox Ring — External	1
8	S729-5L	Drive Shaft (S1029-3) 6 x 12, 6 x 18	1	19	No. 2	Woodruff Key	2
9	S729-6	Spacer	1	20	B56-40-2	Oil Seal (1/4 x 5/8 x 7/8)	1
10	S729-7	Jaw — Male	1	21	3/8 x 3 NF	Hex Socket Cap Screw	1
11	S729-8	Jaw — Female	1	22	3/8 NF	Hex Nut	2

S710W BELT DRIVE ASSEMBLY

INDEX NO.	PART NO.	DESCRIPTION	QTY.	INDEX NO.	PART NO.	DESCRIPTION	QTY.
31	S710W2	Bracket — Belt Tension	1	39	S710W30	Timing Belt (S618, S718)	1
32	S710W3	Roller	2	40	S1NPP7	Ball Bearing	4
33	S710W5	Stand Off	2	41	1/4 x 1/2 NF	Hex Socket Cap Screw	2
34	S710W6	Bearing Spacer	2	42	1/4 x 1 1/2 NF	Hex Socket Cap Screw	2
35	S710W7	Clamp with Teeth	2	43	5/16 x 5/8 NF	Hex Socket Cap Screw	2
36	S710W8	Clamp, Plain	1	44	10-32 x 1/2	Hex Socket Flat Head Cap Screw	4
37	S710W10	Bracket — Belt Anchor (Plain Grinder)	1	45	1/4 x 1/2 NF	Hex Head Cap Screw	2
37	S710W17	Bracket — Belt Anchor (Roller Way Grdr.)	1	46	1/4 x 1 NF	Hex Head Cap Screw	1
38	S710W15	Bracket	1	47	1/4 NF	Hex Jam Nut (HB)	1

S2029, S2029PL SURFACE GRINDER TRANSMISSION ASSEMBLIES

FOR HYDRAULIC TABLE TRAVEL POWERED MODELS

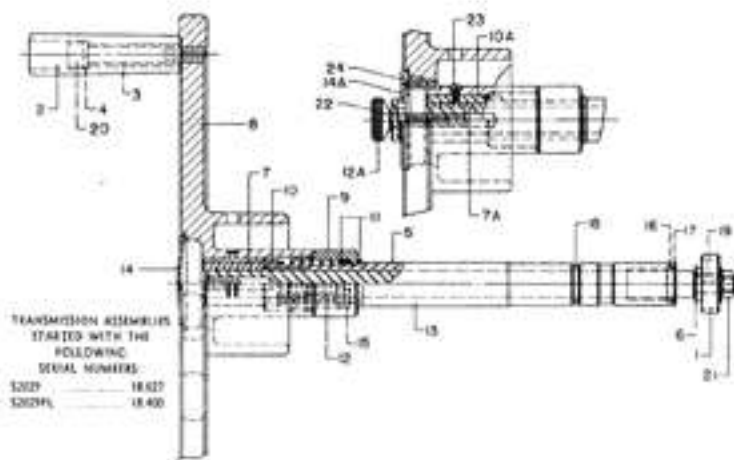

INSTRUCTIONS TO REMOVE TRANSMISSION

1. Remove table of grinder and remove pinion gear (1).
2. Loosen set screw (No. 14 Parts List) which holds transmission stationary shaft No. 13 in saddle. Set screw may be located by removing small bright cap cover, upper left or upper right top of front way shroud.
3. Pull out transmission assembly by pulling on handwheel, straight out.

NOTE: When ordering parts, be sure to check the exact model number of transmission on your machine.

INDEX NO.	PART NO.	DESCRIPTION	QTY.	INDEX NO.	PART NO.	DESCRIPTION	QTY.
1	S610RG	Gear	1	14	S1029D	Cap (S2029)	1
2	S629AB	Grasp Handle	1	14A	S929F	Cap (S2029PL)	1
3	S629ABI	Insert for Grasp Handle	1	15	1/4"	Steel Ball	24
4	S629AW	Thrust Washer	1	16	AA-710-16	Oilite Bearing	2
5	S629S	Drive Shaft	1	17	B56-40-2	Oil Seal (5/8 x 7/8 x 1/8)	1
6	S829W	Washer	1			Trostel	
7	S929B	Bushing (S2029)	1	18	8116-366Y	O-Ring (3/32 x 3/4 x 15/16)	1
7A	S929G	Bushing (S2029PL)	1			No. 14	
8	S929C	Handwheel	1	19	No. 2	Woodruff Key	1
9	S929D	Spring Cage	1	20	3/8 x 3 NF	Hex Socket Cap Screw	1
10	S929E	Threaded Collar	1	21	3/8 NF	Hex Nut	1
10A	S929K	Key (S2029PL)	1	22	5/16 NC	Hex Jam Nut (S2029PL)	1
11	S929R	Bearing Race	1	23	6-32 x 5/16	Sltd. Round Head Machine Screw (S2029PL)	1
12	S929S	Spring	1			Hex Socket Flat Head Screw (S2029PL)	2
12A	S929T	Thumb Screw (S2029PL)	1	24	10-32 x 3/4	Hex Socket Flat Head Screw (S2029PL)	2
13	S2029Y	Stationary Shaft	1				

LUBRICATION SYSTEM

INDEX NO.	PART NO.	DESCRIPTION	QTY.	INDEX NO.	PART NO.	DESCRIPTION	QTY.
1	110.71041	D3174 Lubrication LSP-R	1	18	Y13-02225013	1/4 x 1 NF Hex Hd. Cap Sc. NP	1
2	110.71010	B1061 Compression Sleeve	23	19	110.71019	B3766 Junction Bar 6-Way	1
3	110.71020	B3783 Bushing	12	20	110.71004	A3528 Straight Connector	1
5	S849W	Cover	1	21	110.71025	B6526 Meter Unit FSA 3/0	1
6	S849MS	Spacer	6	23	S825W	Felt Wick	2
7	110.71013	B1095 Nut	10	24	Y11-2212	H500 Hole Plug	2
8	110.71016	B2253 Straight Connector	2	25	110.71018	B3764 Junction Bar 4-Way	1
9	110.71003	A2768 Elbow Connector	3	27	Y14-02130836	8-32 x 5/16 Rd. Hd. Mach. Sc. - NP	1
10	110.71011	B1083 Meter Unit FSA-0	4			A2435 Tubing Clip	1
11	Y13-03210007	10-32 x 1 1/4 Hex Soc. Cap Sc.	6	29	110.71002	1/8 Socket Pipe Plug	4
12	110.71017	B3508 Hose 24"	1	36	Y17-081301	Slide Tube	1
13	110.71022	B4498 Junction Bar 3-Way	1	52	S849BL13	Slide Tube	1
14	110.71015	B1620 Meter Unit FSA-00	2	53	S849BL5	Slide Tube	1
15	110.71026	B6548 Meter Unit FJB3/0	1	54	S849BL7	Elevating Nut Tube	1
16	Y13-02225004	1/4 x 1/2 NF Hex Hd. Cap Sc. - NP	1	55	S849BL11	Tank to Manifold Tube	1
				57	S849BL10	Right Base Way Tube	1
17	Y13-03225012	1/4 x 5/8 NF Hex Soc. Cap Screw	1	58	S849BL12	Crossfeed Nut Tube	1
				59	S849BL2	Column Tube	1
				60	S849BL6	Left Base Way Tube	1