

---

# **S612 MANUAL**

## **SURFACE GRINDER**

---

### P A R T S • L I S T S



K. O. LEE COMPANY • 200 S. HARRISON  
ABERDEEN, SD 57402-1416 • PHONE (605) 225-5820

# S2029, S2029PL SURFACE GRINDER TRANSMISSION ASSEMBLIES

FOR HYDRAULIC TABLE TRAVEL POWERED MODELS

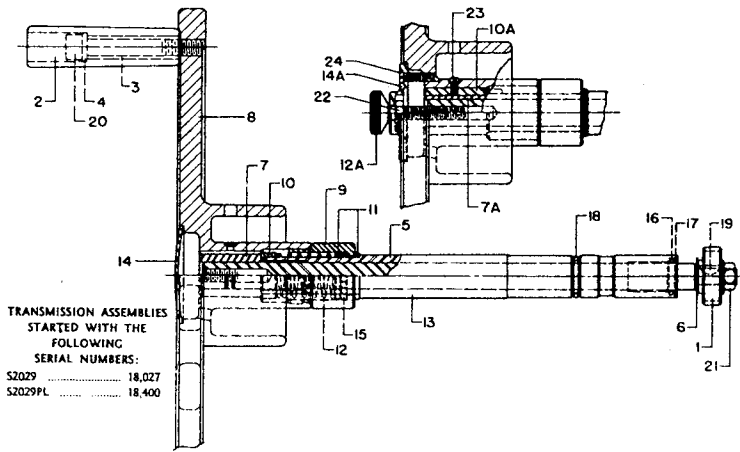

## INSTRUCTIONS TO REMOVE TRANSMISSION

1. Remove table of grinder and remove pinion gear (1).
2. Loosen set screw (No. 14 Parts List) which holds transmission stationary shaft No. 13 in saddle. Set screw may be located by removing small bright cap cover, upper left or upper right top of front way shroud.
3. Pull out transmission assembly by pulling on handwheel, straight out.

NOTE: When ordering parts, be sure to check the exact model number of transmission on your machine.

INDEX NO.	PART NO.	DESCRIPTION	QTY.	INDEX NO.	PART NO.	DESCRIPTION	QTY.
1	S610RG	Gear	1	14	S1029D	Cap (S2029)	1
2	S629AB	Grasp Handle	1	14A	S929F	Cap (S2029PL)	1
3	S629ABI	Insert for Grasp Handle	1	15	1 1/8"	Steel Ball	24
4	S629AW	Thrust Washer	1	16	AA-710-16	Oilite Bearing	2
5	S629S	Drive Shaft	1	17	B56-40-2	Oil Seal (5/8 x 7/8 x 1/8) Trostel	1
6	S829W	Washer	1	18	8116-366Y	O-Ring (3/32 x 3/4 x 15/16) No. 14	1
7	S929B	Bushing (S2029)	1	19	No. 2	Woodruff Key	1
7A	S929G	Bushing (S2029PL)	1	20	3/8 x 3 NF	Hex Socket Cap Screw	1
8	S929C	Handwheel	1	21	3/8 NF	Hex Nut	1
9	S929D	Spring Cage	1	22	5/16 NC	Hex Jam Nut (S2029PL)	1
10	S929E	Threaded Collar	1	23	6-32 x 5/16	Slt'd. Round Head Machine Screw (S2029PL)	1
10A	S929K	Key (S2029PL)	1	24	10-32 x 3/4	Hex Socket Flat Head Screw (S2029PL)	2
11	S929R	Bearing Race	1				
12	S929S	Spring	1				
12A	S929T	Thumb Screw (S2029PL)	1				
13	S2029Y	Stationary Shaft	1				

## LUBRICATION SYSTEM

INDEX NO.	PART NO.	DESCRIPTION	QTY.	INDEX NO.	PART NO.	DESCRIPTION	QTY.
1	110.71041	Lubrication LSP-R D3174	1	18	Y13-02225013	Hex Hd. Cap Screw 1/4 x 1 NF NP	1
2	110.71010	Compression Sleeve	23	19	110.71019	Junction Bar 6-Way B3766	1
3	110.71020	Bushing B3783	12	20	110.71004	Straight Connector A3528	1
5	S849W	Bracket	1	21	110.71025	Meter Unit FSA3/0 B6526	1
6	S849MS	Spacer	6	23	S625W	Felt Wick	2
7	110.71013	Nut B1095	10	24	Y11-2212	Hole Plug H500	2
8	110.71016	Straight Connector B2253	2	25	110.71018	Junction Bar 4-Way B3764	1
9	110.71003	Elbow Connector A2768	3	27	Y14-02130836	Rd. Hd. Mach. Sc. 8-32 x 5/16 NP	1
10	110.71011	Meter Unit FSA-0, B1083	4	29	110.71002	Tubing Clip A2435	1
11	Y13-03210007	Hex Soc. Cap Sc. 10-32 x 1 1/4	6	36	Y17-081301	Socket Pipe Plug 1/8"	4
12	110.71017	Hose 24" B3508	2	52	S849BL13	Slide Tube	1
13	110.71022	Junction Bar 3-Way B4498	1	53	S849BL5	Slide Tube	1
14	110.71015	Meter Unit FSA-00, B1620	2	55	S849BL11	Tank to Manifold Tube	1
15	110.71026	Meter Unit FJB3/0 B6548	1	57	S849BL10	Right Base Way Tube	1
16	Y13-02225004	Hex Hd. Cap Sc. 1/4 x 1/2 NF NP	1	59	S849BL2	Column Tube	1
17	Y13-03225012	Hex Soc. Cap Screw 1/4 x 5/8 NF	1	60	S849BL6	Left Base Way Tube	1

# MAIN ASSEMBLY DRAWING

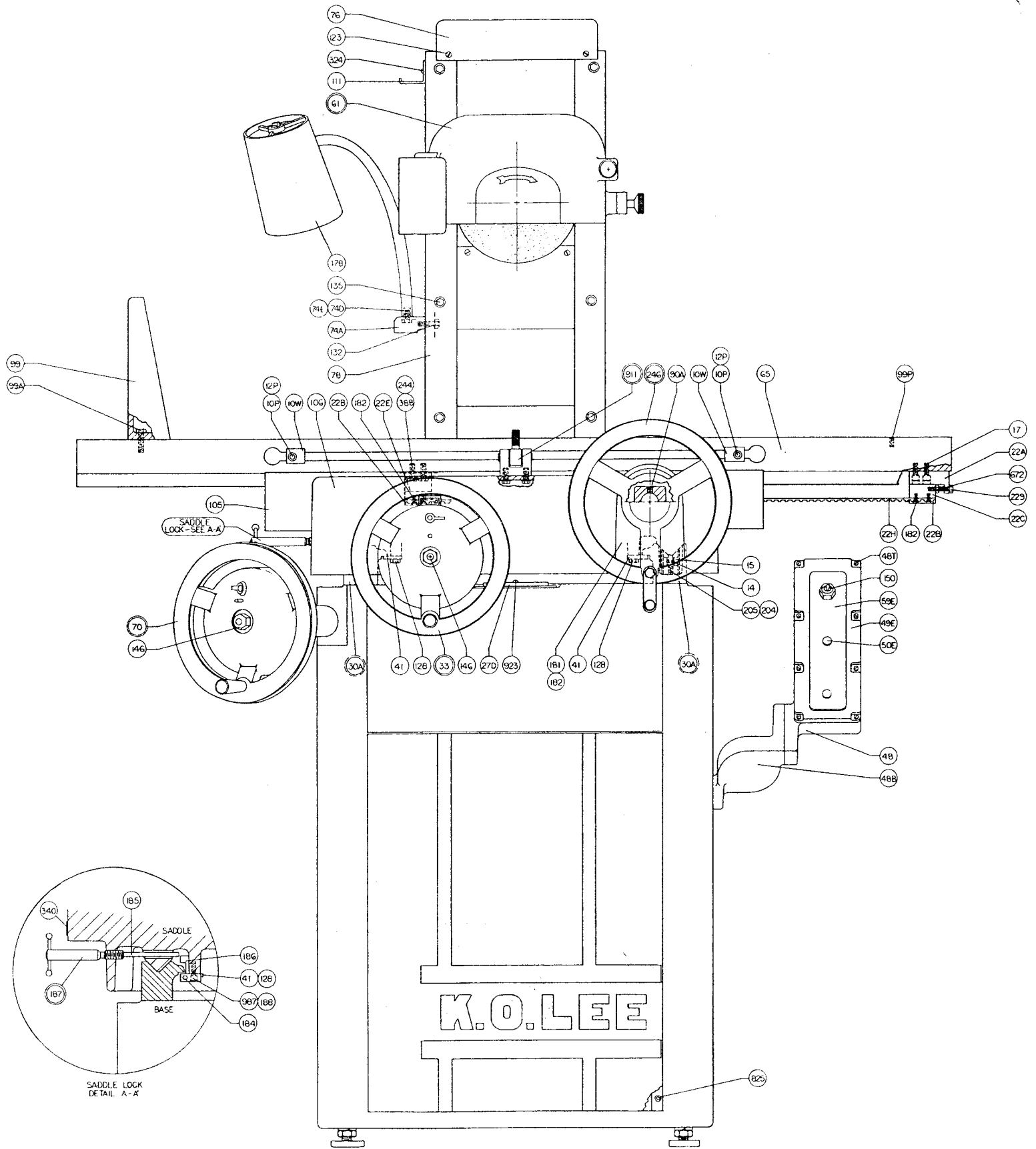

# S1029-3 SURFACE GRINDER TRANSMISSION ASSEMBLY WITH BELT DRIVE

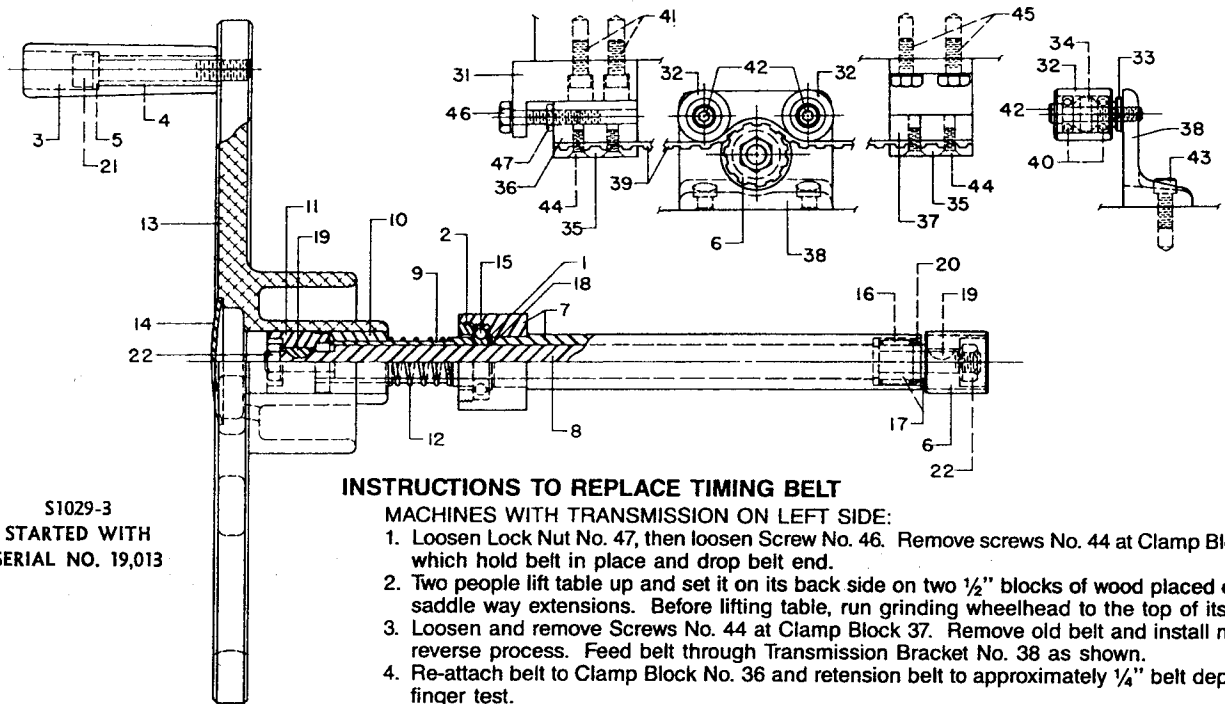

S1029-3  
STARTED WITH  
SERIAL NO. 19,013

## INSTRUCTIONS TO REPLACE TIMING BELT

### MACHINES WITH TRANSMISSION ON LEFT SIDE:

1. Loosen Lock Nut No. 47, then loosen Screw No. 46. Remove screws No. 44 at Clamp Block No. 36, which hold belt in place and drop belt end.
2. Two people lift table up and set it on its back side on two 1/2" blocks of wood placed on the rear saddle way extensions. Before lifting table, run grinding wheelhead to the top of its travel.
3. Loosen and remove Screws No. 44 at Clamp Block 37. Remove old belt and install new belt by reverse process. Feed belt through Transmission Bracket No. 38 as shown.
4. Re-attach belt to Clamp Block No. 36 and retension belt to approximately 1/4" belt depression by finger test.

### MACHINES WITH TRANSMISSION ON RIGHT SIDE:

Reverse above procedure, working first from right end of machine where tension screw is located.

INDEX NO.	PART NO.	DESCRIPTION	QTY.	INDEX NO.	PART NO.	DESCRIPTION	QTY.
1	A604X	Washer	1	12	S729-10	Spring	1
2	B805N	Lock Nut	1	13	S1029C	Handwheel	1
3	S629AB	Grasp Handle	1	14	S1029D	Cap	1
4	S629ABI	Valve Guide	1	15	S7K	Ball Bearing	1
5	S629AW	Thrust Washer	1	16	BH-1010	Needle Bearing	1
6	S710W4	Pulley — Timing Belt	1	17	1R-061012	Inner Race	1
7	S729-4L	Stationary Shaft Assembly	1	18	RS-62	Spirolox Ring — External	1
8	S729-5L	Drive Shaft (S1029-3) 6 x 12, 6 x 18	1	19	No. 2	Woodruff Key	2
9	S729-6	Spacer	1	20	B56-40-2	Oil Seal (1/8 x 5/8 x 7/8)	1
10	S729-7	Jaw — Male	1	21	3/8 x 3 NF	Hex Socket Cap Screw	1
11	S729-8	Jaw — Female	1	22	3/8 NF	Hex Nut	2

## S710W BELT DRIVE ASSEMBLY

INDEX NO.	PART NO.	DESCRIPTION	QTY.	INDEX NO.	PART NO.	DESCRIPTION	QTY.
31	S710W2	Bracket — Belt Tension	1	39	S710W30	Timing Belt (S618, S718)	1
32	S710W3	Roller	2	40	S1NPP7	Ball Bearing	4
33	S710W5	Stand Off	2	41	1/4 x 1/2 NF	Hex Socket Cap Screw	2
34	S710W6	Bearing Spacer	2	42	1/4 x 1 1/2 NF	Hex Socket Cap Screw	2
35	S710W7	Clamp with Teeth	2	43	5/16 x 5/8 NF	Hex Socket Cap Screw	2
36	S710W8	Clamp, Plain	1	44	10-32 x 1/2	Hex Socket Flat Head Cap Screw	4
37	S710W10	Bracket — Belt Anchor (Plain Grnder)	1	45	1/4 x 1/2 NF	Hex Head Cap Screw	2
37	S710W17	Bracket — Belt Anchor (Roller Way Grdr.)	1	46	1/4 x 1 NF	Hex Head Cap Screw	1
38	S710W15	Bracket	1	47	1/4 NF	Hex Jam Nut (HB)	1

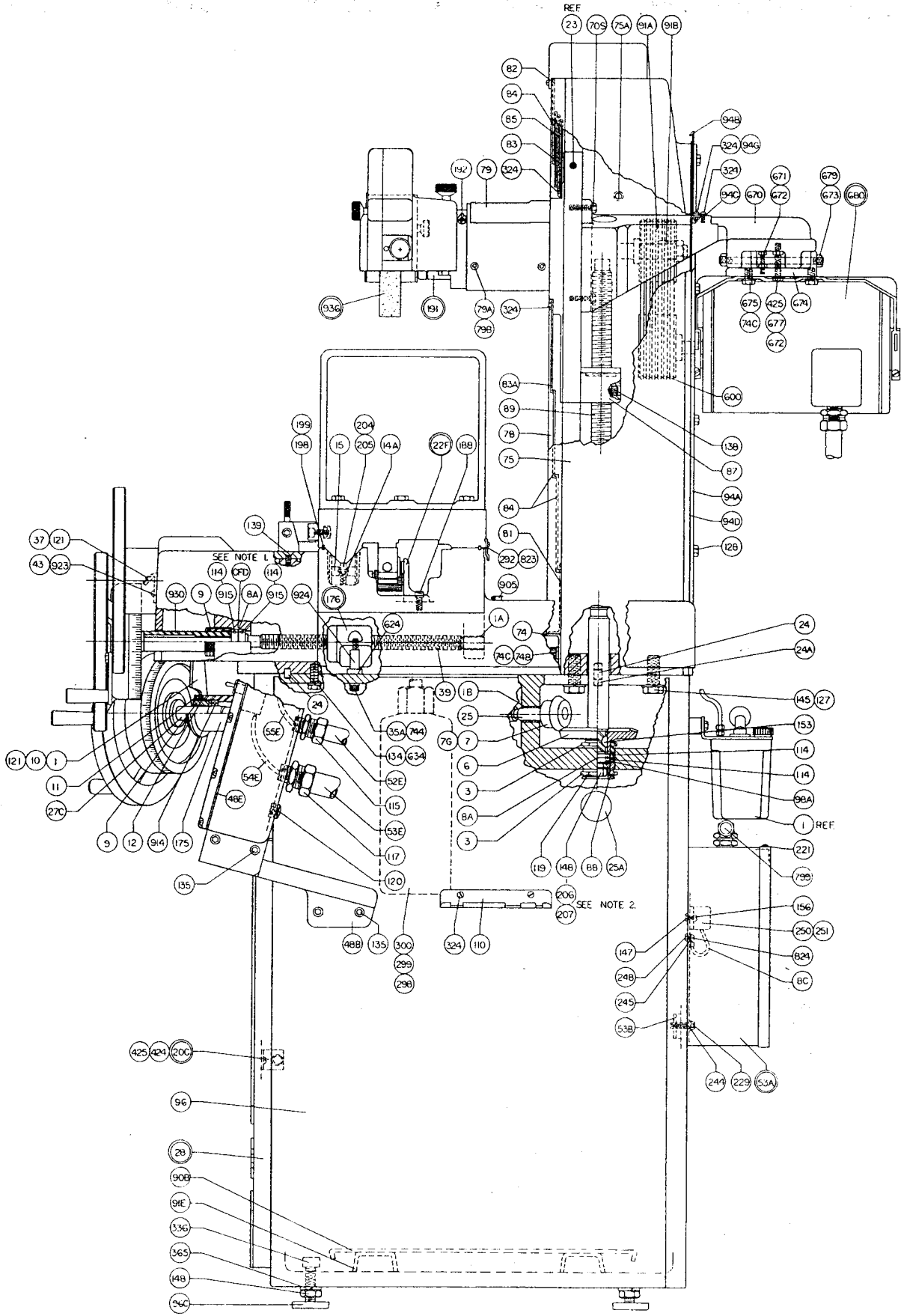

INDEX NO.	PART NO.	DESCRIPTION	QTY.
221	Y14-12130605	S. T. Pan Sl. Bind. Hd. 6 x 3/8 Type A	1
229	Y13-02225015	Hex Hd. Cap Sc. 1/4 x 1 1/4 NF NP	5
244	Y16-082502	Lock Washer — Regular 1/4	6
245	Y16-081801	Lock Washer 3/16 No. 10	1
246	S1029-3	Transmission	1
248	Y16-02211011	Std. Light Hex Nut 10-32 Brass	1
250	Y18-1609	End Block CR151C10	1
251	Y18-1608	Terminal Block CR151C2200	8
292	BA930HE	Dust Snield	1
298	Y11-01019	Clr. Plastic Bottle 28/410 320Z	1
299	BA905N	Special Nut	1
300	Y17-072513	Long Pipe Nipple 1/4 x 3	1
324	Y14-02231058	Rd. Hd. Mach. Sc. 10-32 x 1/4 NP	12
336	Y15-03115013	Sq. Hd. Set Sc. 1/2 x 2 1/2 NC Cup Pt	4
340	Y12-0124	KO-40 Name Plate	1
365	Y16-085007	Lock Washer 1/2	4
388	Y13-02225007	Hex Hd. Cap Sc. 1/4 x 5/8 NF NP	2
424	Y14-02231069	Rd. Hd. Mach. Sc. 10-32 x 1/2 NP	2
425	S6012W	Washer (No. 12)	2
600	Y11-1931	O-Ring AS568-349	6
624	B6024NS	Spacer for Feed Bar	1
634	Y16-134402	External Shakeproof Washer 7/16	6
670	S823S	Motor Bracket	1
671	Y13-02225013	Hex Head Cap Sc. 1/4 x 1 NF NP	1
672	Y16-02222527	Std. Light Jam Nut 1/4 NF Plated	3
673	Y16-02223165	Std. Light Jam Nut 5/16 NF NP	2
674	S623BL	Bracket	1
675	Y13-02231027	Hex Hd. Cap Sc. 5/16 x 1/2 NF NP	4
677	S623BM	Special Screw	1
679	S623BA	Axle	1
680	S823G	Motor Pulley Assembly	1
744	Y16-083805	Lock Washer — Light 3/8	2
799	Y17-0537516	3/4" 90° Connector	1
823	Y13-04221001	But. Hd. Soc. Cap Sc. 10-32 x 1/4	5
824	Y14-02241066	Rd. Hd. Mach. Sc. 10-32 x 3/8 Brass	1
825	Y13-04211009	But. Hd. Soc. Cap Sc. 10-32 x 1/2	5
905	Y11-1703	Gits Oiler No. 503 (0134-000001)	2
911	B911CS	Center Stop Block	1
914	Y11-1251	Bearing WC87501	1
923	Y14-11231010	S. T. Rd. Hd. Sc. 10-32 x 3/8 Type F	3
924	BA924NB	Feed Bar	1
930	BA930SS	Spacer	1
936	S936CL8W	Wheel and Collet Assembly	1
987	BA919H	Holder for Axle	2
CFD	BA930SB	Bushing	1
*	KO-111	Caution Label	1
*	Y18-1103	Wire Tie 41-609, TY-23M	4
*	Y18-0101	Wire Nut Connector 767, (73B)	6
*	Y12-0101	KO-5 Name Plate	1
*	Y12-0194	KO-61H Instruction Plate	1
*	Y12-0152	KO-62 Name Plate	1
*	Y12-01104	Danger HV KO-100HV	1
*	Y14-02130001	Rd. Hd. Met. Dr. Sc. 0 x 3/16 Type Y	4
*	Y12-0157	KO-68 Protective Mat	1
*	Y12-0137	KO-50 Name Plate (Repl. KO-39)	1
*	Y12-0127	KO-43 Name Plate	1
*	Y12-0140	KO-53 Name Plate	1
*	Y12-0141	KO-53A Name Plate	1
*	Y12-0126	KO-42 Name Plate	1
*	Y12-0125	KO-41 Name Plate	1
ACCESSORY	PV8JM60	Grinding Wheel	1
ACCESSORY	S681	Diamond Dresser	1
ACCESSORY	B936W	Spanner Wrench	1
ACCESSORY	S895	Wrench	1
ACCESSORY	S896	Wrench	1
SHIPPING	Y16-03213102	Heavy Hex Nut 5/16 NF NP	4
SHIPPING	Y16-03113810	Heavy Hex Nut 3/8 NC NP	4
SHIPPING	Y13-02138106	Hex Hd. Cap Sc. 3/8 x 5 1/2 NC NP	4
SHIPPING	BA900RL	Table Clamp Rod	4
SHIPPING	S600RC	Rod Clamp	4
SHIPPING	S600GW	Special Washer 3/8	8

# S612 SURFACE GRINDER PARTS LIST

INDEX NO.	PART NO.	DESCRIPTION	QTY.
1	B330BP	Pointer Bracket	1
1A	Y11-1404	Bearing-Needle M10121	1
1B	B629M	Bushing	1
3	B805M	Adjusting Nut	2
6	S626G	Gear	1
7	S626P	Pinion Gear	1
7G	Y15-02113163	Hex Soc. Set Sc. $\frac{5}{16}$ x $\frac{5}{16}$ NC Cup	1
8A	B830SY5	Circular Shim	2
8C	B865BG	Electric Wire	1
9	BA805N	Lock Nut	2
10	BA805P	Indicator Plate	1
10P	B810P	T-Slot Plate	2
10W	B810W	Adjustable Stop	2
11	BA805R	Lock Ring	1
12	BA805Y	Washer	1
12P	Y13-03231024	Hex Soc. Cap Sc. $\frac{5}{16}$ x $\frac{3}{4}$ NF	2
14	B930RP2	Oil Roller Plate	8
14A	B930RP	Oil Roller Plate	6
15	B1030PR	Oil Roller	14
17	Y13-03225012	Hex. Soc. Cap Screw $\frac{1}{4}$ x $\frac{5}{8}$ NF	2
20C	B965DD	Door Catch Assembly	1
22A	S710W2	Belt Tension Bracket	1
22B	S710W7	Clamp with Teeth	2
22C	S710W8	Plain Clamp	1
22E	S710W10	Belt Anchor Bracket	1
22F	S710W16	Bracket and Roller	1
22H	S710W26	Timing Belt	1
24	BA905DP	Dowel Pin	3
24A	BA905DPL	Dowel Pin	1
25	BA905E	Handwheel Shaft	1
25A	BA905HP	Hole Plug	4
27C	BA909S	Spacer	1
27D	BA905CP	Cover Plate	1
28	BA965DH	Door and Hinge	1
30A	B2005A	Base Way Vee Assembly	1
33	B6012C	Handwheel Assembly	1
35A	Y13-03238038	Hex Soc. Cap Sc. $\frac{3}{8}$ x $1\frac{3}{4}$ NF	2
37	BA930P	Indicator Plate	1
39	BA930SF	Feed Screw	1
41	BA930TT	Hold Down-Short	4
43	B6030WB	Bracket for Index	1
48	BA967B	Switch Box	1
48B	BA967A4	Bracket for Box	1
48E	BA967G	Gasket	1
48T	Y14-11231013	S. T. Rd. Hd. Mach. Sc. 10-32 x $\frac{3}{4}$ NP	8
49E	BA967C	Cover	1
50E	BA967CP	Plug	2
52E	BA967H54	Flexible Conduit	1
53A	BA967KB	Cutout Box	1
53B	BA967KC	Screw Clamp	4
53E	BA967J32	Flexible Conduit	1
54E	BA967W52	Power Wire	3
55E	BA967W72	Power Wire	3
59E	Y12-0115	KO-29 Name Plate	1
61	S709	Wheel Guard Assembly	1
65	S610	Table	1
70	S912D	Handwheel	1
70S	Y13-02231033	Hex Hd. Cap Sc. $\frac{5}{16}$ x $\frac{7}{8}$ NF NP	4
74	S625A	Guard Stop	1
74A	S625B	Bracket for Lamp	1
74B	Y13-03131067	Hex Soc. Cap Sc. $\frac{5}{16}$ x $\frac{1}{2}$ NC	2
74C	Y16-06233107	Steel Washer $\frac{5}{16}$ NF Plated	6
74D	B923LS	Lamp Stud	1
74E	Y13-02231030	Hex Hd. Cap Sc. $\frac{5}{16}$ x $\frac{5}{8}$ NF NP	1
75	S625C	Box Column	1
75A	Y11-2201	Nylon Hole Plug No. 434 (H437)	2
76	S625CP	Column Cap	1
78	S625R	Guide Rail	2
79	S625S-1	Column Slide	1

INDEX NO.	PART NO.	DESCRIPTION	QTY.
79A	S625SP	Plug	4
79B	Y15-02214448	Hex Soc. Set Sc. $\frac{7}{16} \times \frac{3}{8}$ NF Cup	4
81	S625TAS	Telescoping Guard	1
82	S625TB	Telescoping Guard	1
83	S625TC	Telescoping Guard	1
83A	S625TCS	Telescoping Guard	1
84	S625TD	Telescoping Guard	3
85	S625TE	Telescoping Guard	1
87	S626B-1	Column Feed Nut	1
88	S626FC	Friction Collar	1
89	S626SF	Elevating Screw	1
90A	Y15-02232526	Hex Soc. Set Sc. $\frac{1}{4} \times \frac{1}{4}$ NF $\frac{1}{2}$ Dog	1
90B	BA905BW	Plate for Tank	1
91A	S655H3	Pulley	1
91B	S855K	Key	1
91E	BA905BUL	Bracket	2
94A	S826TG	Guide Bar	2
94B	S826TR	Removable Guard	1
94C	S826TU	Upper Guard	1
94D	S826TL	Lower Guard	1
94G	Y16-02211012	Std. Light Hex Nut 10-32 NP	2
96	BA905BC	Cabinet Base	1
96C	BA905GR	Leveling Pad Assembly	4
98A	S726A	Bushing	1
99	S610G	Guard	1
99A	Y13-02225010	Hex Hd. Cap Sc. $\frac{1}{4} \times \frac{3}{4}$ NF NP	3
99P	Y15-02212525	Hex Soc. Set Sc. $\frac{1}{4} \times \frac{1}{4}$ NF Cup	3
105	BA930VT	Saddle	1
106	B6030WC	Saddle Way Shroud	1
110	S890B	Tool Rack	1
111	S890C	Rack for Wrench	1
114	Y11-1219	Bearing S7K2	4
115	Y17-0515011	Straight Connector 75-221 $\frac{1}{2}$ "	2
117	Y17-0517515	Straight Connector 75-222 $\frac{3}{4}$ "	2
119	Y16-090005	Wavy Spring Washer 8Z $1\frac{1}{8}$	1
120	Y11-2205	Close Up Plug $\frac{1}{2}$ " Cup No. 1	1
121	Y14-11131301	S. T. Rd. Hd. Sc. 2 x $\frac{1}{8}$ Type F, NP	4
123	Y14-11231011	S. T. Rd. Hd. Sc. 10-32 x $\frac{1}{2}$ Type F	2
127	Y13-02150128	Hex Hd. Cap Sc. $\frac{1}{2} \times 1\frac{3}{4}$ NC NP	4
128	Y13-02225004	Hex Hd. Cap Sc. $\frac{1}{4} \times \frac{1}{2}$ NF NP	18
132	Y13-02131079	Hex Hd. Cap Sc. $\frac{5}{16} \times 1\frac{1}{4}$ NC NP	2
134	Y13-02244145	Hex Hd. Cap Sc. $\frac{7}{16} \times 1\frac{3}{4}$ NF NP	6
135	Y13-03131069	Hex Soc. Cap Sc. $\frac{5}{16} \times \frac{3}{4}$ NC	14
138	Y13-03231030	Hex Soc. Cap Sc. $\frac{5}{16} \times 2$ NF	2
139	Y13-05222506	Fl. Hd. Soc. Cap Sc. $\frac{1}{4} \times \frac{5}{8}$ NF	4
145	Y16-135001	External Shakeproof Washer $\frac{1}{2}$	4
146	Y16-02224436	Std. Light Jam Nut $\frac{7}{16}$ NF NP	2
147	Y16-02110808	Std. Light Hex Nut 8-32 NC NP	2
148	Y16-02125063	Std. Light Jam Nut $\frac{1}{2}$ NC NP	5
150	Y18-1218	Switch 0140-3020	1
150	Y18-1207	Toggle Boot N1030B	1
153	Y16-2301	Woodruff Key No. 2	4
156	Y14-02130839	Rd. Hd. Mach. Sc. 8-32 x $\frac{3}{8}$ NP	2
175	BA905H	Housing	1
176	BA924-1	Feed Nut Assembly	1
178	Y18-06901	Light Fixture (0618-E) 0618-3	1
181	BA930WA3	Segment	1
182	Y13-05221002	Flat Hd. Soc. Cap Sc. 10-32 x $\frac{1}{2}$	6
184	BA919A	Axle	1
185	BA919P	Plunger	1
186	BA919L	Lock	1
187	BA919D	Lock Screw Assembly	1
188	Y13-03231023	Hex Soc. Cap. Sc. $\frac{5}{16} \times \frac{5}{8}$ NF	4
191	S6055CL	Quill Assembly	1
192	Y11-1906	O-Ring 8041 $\frac{1}{16} \times 3 \times 3\frac{1}{8}$	1
198	B930HES	Shim for Dust Shield	2
199	B930HD	Saddle Way Dust Shield	1
204	S2030NP	Nylon Plug	6
205	B931WS	Spring	6
206	B826N	Special Nut	1
207	B826R	Spacer	1